

INTERNATIONAL

R

**PRODUCT CATALOGUE
INTERNATIONAL MARKETS**

2021



Autonomous residential | Centralized residential | Service Industry | Industrial Process

March **2021**

Three flue gas passes steel jet burner boilers

RTS 3S

Oil products are in conformity with ErP Directive (EU Regulation Nr. 813/2013). Gas products up to 400 kW only for replacement, till 1st January 2018, in conformity of point 2 (G) Article 1 of EU Regulation N. 813/2013.



LIGHT OIL

- Oil products are in conformity with Directive 2009/125/EC
- Single-piece steel boilers with three flue gas passes
- The particular geometry of the heat exchanger allows to reduce the permanence time of flue gases in the high temperature zones while decreasing in this way the formation of NO_x for low polluting emissions

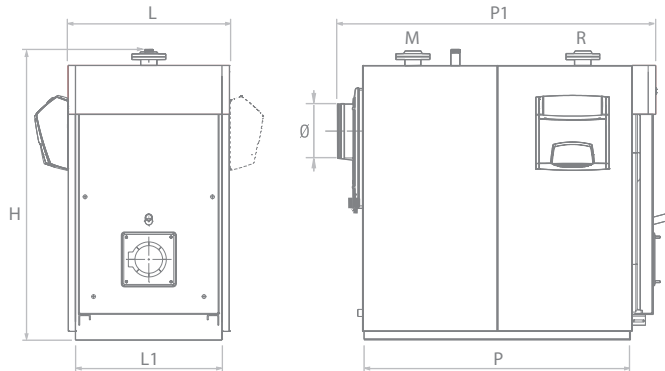

Description	H mm	L mm	P mm	L1 mm	P1 mm	M Ø	R Ø	Ø mm	Net weight kg
RTS 90 3S	1205	660	860	580	1155	2"	2"	180	335
RTS 115 3S	1285	710	1010	640	1330	2"	2"	200	450
RTS 166 3S	1390	760	1180	690	1500	2" 1/2	2" 1/2	250	515
RTS 217 3S	1390	760	1180	690	1500	2" 1/2	2" 1/2	250	535
RTS 255 3S	1524	820	1296	750	1660	2" 1/2	2" 1/2	250	715
RTS 349 3S	1490	820	1596	750	1960	DN80	DN80	250	840
RTS 448 3S	1685	890	1692	790	2085	DN80	DN80	300	1160
RTS 511 3S	1685	890	1692	790	2085	DN80	DN80	300	1160
RTS 639 3S	1820	1000	1965	900	2375	DN100	DN100	350	1500
RTS 850 3S	1920	1047	2236	980	2657	DN125	DN125	350	2075
RTS 1160 3S	2080	1147	2533	1070	2954	DN125	DN125	400	2575
RTS 1450 3S	2222	1237	2754	1160	3173	DN150	DN150	450	3390

Its vertical design and reduced width (narrow range) allows an easy installation even in tiny plant rooms. The flue pipes are equipped with removable stainless steel turbulators, which allow to optimize the efficiency of the heat exchange without increasing head losses. The door features an ambidextrous opening and is provided with a peephole with pressure intake. Casing is made of stove-enamelled sheet. Shell and flue gas zone are easy to reach for maintenance. The control panel should be ordered separately.

- High efficiency both punctual and seasonal
- Operation at modulating temperature (minimum allowed return temperature 50 °C)
- Several solutions thanks to the combination with RIELLOtech control panels
- Maximum operating pressure: 6 bar.

TECHNICAL DATA

Description	Output kW	Input kW	Efficiency Pn (80°-60 °C)	Efficiency (30% Pn) %	Notes	Code
RTS 90 3S	85,1	90	94,5	98,5	(1)(2)	20042418
RTS 115 3S	108,3	115	94,2	98,5	(1)(2)	20031973
RTS 166 3S	157,4	166	94,8	98,5	(1)(2)	20031974
RTS 217 3S	207,5	217	95,6	98,5	(1)(2)	20031976
RTS 255 3S	244,0	255	95,7	98,5	(1)(2)	20031977
RTS 349 3S	334,7	349	95,9	98,5	(1)(2)	20031978
RTS 448 3S	427,8	448	95,5	98,5	(3)	20031979
RTS 511 3S	488,0	511	95,5	98,5	(3)	20031980
RTS 639 3S	610,2	639	95,5	98,5	(3)	20042417
RTS 850 3S	811,8	850	95,5	98,5	(3)	20044152
RTS 1160 3S	1107,8	1160	95,5	98,5	(3)	20047381
RTS 1450 3S	1384,8	1450	95,5	98,5	(3)	20047391

Maximum operating pressure 5 bar for 90 model.

Maximum operating pressure 6 bar for the other models.

Minimum temperature of water return (to the boiler): 50 °C.

(1) Gas products only for replacement, till 1st January 2018, in conformity of point 2 (G) Article 1 of Regulation EU N. 813/2013.

(2) Oil product are in conformity with ErP Directive (EU Regulation Nr. 813/2013)

(3) For orders please contact Sales Department.

ACCESSORIES

Description	Code
MECHANICAL ACCESSORIES	
Burner flange	4031188
Burner flange	4031196
Burner flange	4031197
Burner flange	4031198
Burner flange	20043900
Burner flange	20047680

CONTROL PANELS

Description	Installation	Code	Boiler model
RIELLOtech CLIMA COMFORT	Vertical	4031069	All models
RIELLOtech PRIME	Vertical	20010820	All models
RIELLOtech PRIME ACS	Vertical	20010437	All models

Climate management with RIELLOtech Clima Comfort.

Thermostatic management with RIELLOtech PRIME.

NOTE: for specific accessories, connection MODBUS and more details on control panels, please refer to page 325.

RECOMMENDED COMBINATIONS WITH BURNERS - EU COUNTRIES

Description	Back-pressure in combustion chamber (mbar)	Gas burner										Burner flange	Control panels																								
		Yellow flame (Standard)					Blue flame (Low NOx)																														
		Two stage		Modulating			Mechanical cam		Electronic cam																												
		-		-			-		O ₂ control																												
		-		-			-		+Inverter																												
		RS 50 TC	RS 70 TC	RS 100 TC	RS 130 TC	RS 150 TC	RS 50/M MZ TC	RS 70/M TC	RS 100/M TC	RS 130/M TC	RS 150/M TC	RS 55/M BLU TC	RS 68/M BLU TC	RS 120/M BLU TC	RS 160/M BLU TC	RS 55/E BLU	RS 68/E BLU	RS 120/E BLU	RS 160/E 02 BLU TC	RS 160/E 02 BLU TL	RS 120/EV 02 BLU TC	RS 160/EV 02 BLU TC	Burner flange	Burner flange	Burner flange	Burner flange	RielloTech Prime	RielloTech Klima Comfort	Two stage burner management kit	3-point modulation kit							
		3784702	3785102	3785302	3785502	20044636	3781622	3789610	3789710	3789810	20044638	20038484	3897406	3897606	3788006	20038491	3897432	3897632	3788032	20165996	20164535	20154943	20158956	4031197	20043900	20047680	4031196	20010820	4031069	4031067	20013035						
RTS 448 3S	2,9	•																																			
	2,9						•																														
	2,9											•																									
	2,9														•																						
RTS 511 3S	5,4	•																																			
	5,4						•																														
	5,4											•																									
	5,4														•																						
RTS 639 3S	5,2		•																																		
	5,2							•																													
	5,2											•																									
	5,2														•																						
RTS 850 3S	6,7			•																																	
	6,7							•																													
	6,7																																				
	6,7																																				
	6,7																																				
RTS 1160 3S	3,9			•																																	
	3,9																																				
	3,9																																				
	3,9																																				
	3,9																																				
RTS 1450 3S	4,6				•																																
	4,6																																				
	4,6																																				
	4,6																																				
	4,6																																				

NOTE: the gas burners must be completed with the gas train.

NOTE: for specific accessories, connection MODBUS and more details on control panels, please refer to page 325.

Description	Back-pressure in combustion chamber (mbar)	Oil burner								Dual fuel burner	Burner accessory	Burner flange	Control panels																	
		Yellow flame (Standard)				Blue flame (Low NOx)																								
		Two stage		Modulating		Two stage		Modulating																						
		-		Mechanical cam		-		Mechanical cam																						
		RL 50 TC	RL 70 TC	RL 100 TC	RL 130 TC	RL 50/M TC	RL 70/M TC	RL 100/M TC	RL 130/M TC	B66.1D	B67.1D	RL 22 BLU	RL 32 BLU	RL 42 BLU	RL 55/M BLU	RL 85/M BLU	RLS 68/M MX TC	RLS 120/M MX TC	RLS 160/M MX TC	RWF 50.2	RWF 50.2	Burner flange	Burner flange	Burner flange	Burner flange	RielloTech Prime	RielloTech Clima Comfort	Two stage burner management kit	3-point modulation kit	
RTS 90 3S	1,0	3474632	3475032	3475232	3475432	20166502	20166463	20166481	20166486	20015693	20015696	20027479	20027481	20027567	20169338	20169330	20147784	20147786	20147789	20082208	20099869	20043900	4031188	4031196	4031198	20010820	4031069	4031067	20013035	
RTS 115 3S	1,4																													
RTS 166 3S	1,8																													
RTS 217 3S	2,7																													
RTS 255 3S	2,9																													
RTS 349 3S	3,6																													
RTS 448 3S	2,9																													
	2,9																													
	2,9																													
	2,9																													
	2,9																													
RTS 511 3S	5,4																													
	5,4																													
	5,4																													
	5,4																													
RTS 639 3S	5,2																													
	5,2																													
	5,2																													
	5,2																													
RTS 850 3S	6,7																													
	6,7																													
	6,7																													
	6,7																													
RTS 1160 3S	3,9																													
	3,9																													
	3,9																													
RTS 1450 3S	4,6																													
	4,6																													
	4,6																													

NOTE: for specific accessories, connection MODBUS and more details on control panels, please refer to page 325.

HYBRID SYSTEMS

HEAT PUMPS

WALL-HUNG BOILERS

FLOOR-STANDING BOILERS

WATER-HEATERS

SOLAR THERMAL AND CYLINDERS

CENTRALIZED HEATING

AIR CONDITIONING

TERMINAL UNITS

SYSTEM COMPLEMENTARY ITEMS

HOT AIR GENERATORS

RECOMMENDED COMBINATIONS WITH BURNERS – EXTRA EU COUNTRIES

Description	Back-pressure in combustion chamber (mbar)	Gas burner										Burner flange	Control panels								
		Yellow flame (Standard)																			
		Two stage					Modulating														
		-					Mechanical cam														
		-					-														
		RS 34 MZ TC	RS 44 MZ TC	RS 50 TC	RS 70 TC	RS 100 TC	RS 130 TC	RS 150 TC	RS 34/M MZ TC	RS 44/M MZ TC	RS 50/M MZ TC	RS 70/M TC	RS 100/M TC	RS 130/M TC	RS 150/M TC	Burner flange	Burner flange	RielloTech Prime	RielloTech Klima Comfort	Two stage burner management kit	3-point modulation kit
RTS 166 3S	1,8	●																●	●	●	
	1,8								●										●	●	●
RTS 217 3S	2,7	●																●	●	●	
	2,7								●										●	●	●
RTS 255 3S	2,9	●																●	●	●	
	2,9								●										●	●	●
RTS 349 3S	3,6		●															●	●	●	
	3,6								●										●	●	●
RTS 448 3S	2,9			●														●	●	●	
	2,9									●									●	●	●
RTS 511 3S	5,4			●														●	●	●	
	5,4									●									●	●	●
RTS 639 3S	5,2				●													●	●	●	
	5,2										●								●	●	●
RTS 850 3S	6,7					●											●	●	●	●	
	6,7											●							●	●	●
RTS 1160 3S	3,9						●									●		●	●	●	
	3,9												●			●			●	●	●
RTS 1450 3S	4,6							●										●	●	●	
	4,6													●					●	●	●

NOTE: the gas burners must be completed with the gas train.
 NOTE: for specific accessories, connection MODBUS and more details on control panels, please refer to page 325.

HYBRID SYSTEMS

HEAT PUMPS

WALL-HUNG BOILERS

FLOOR-STANDING BOILERS

WATER-HEATERS

SOLAR THERMAL AND CYLINDERS

CENTRALIZED HEATING

AIR CONDITIONING

TERMINAL UNITS

SYSTEM COMPLEMENTARY ITEMS

HOT AIR GENERATORS

Description	Back-pressure in combustion chamber (mbar)	Gas burner														Burner flange	Control panels																		
		Blue flame (Low NOx)																																	
		Monostadio		Bistadio		Modulating																													
		-	-	Mechanical cam				Electronic cam																											
															O ₂ control					O ₂ control +Inverter															
		BS3	BS3D	BS3/M	RS 25/M BLU TC	RS 35/M BLU TC	RS 55/M BLU TC	RS 68/M BLU TC	RS 120/M BLU TC	RS 160/M BLU TC	RS 25/E BLU	RS 35/E BLU	RS 45/E BLU	RS 55/E BLU	RS 68/E BLU	RS 120/E BLU	RS 160/E BLU	RS 120/E 02 BLU TC	RS 160/E 02 BLU TL	RS 120/EV 02 BLU TC	RS 160/EV 02 BLU TC	Burner flange	Burner flange	Burner flange	Burner flange	Rielotech Prime	Rielotech Clima Comfort	Two stage burner management kit	3-point modulation kit						
		3761316	3761776	3762350	3910510	3910610	20038484	3897406	3897606	3788006	3910710	3910810	3897332	20038491	3897432	3897632	3788032	20165996	20164535	20154943	20158956	20043900	20047680	4031196	4031198	4031197	20010820	4031069	4031067	20013035					
RTS 90 3S	1,0	●																																	
	1,0		●																																
	1,0			●																															
RTS 115 3S	1,4	●																																	
	1,4		●																																
	1,4			●																															
RTS 166 3S	1,8	●																																	
	1,8		●																																
	1,8			●																															
RTS 217 3S	2,7				●																					●									
	2,7										●														●										
RTS 255 3S	2,9				●																														
	2,9											●																							
RTS 349 3S	3,6					●																													
	3,6											●																							
RTS 448 3S	2,9						●																			●									
	2,9												●																						
RTS 511 3S	5,4						●																			●									
	5,4													●												●									
RTS 639 3S	5,2							●																		●									
	6,7								●																										
RTS 850 3S	6,7																																		
	6,7																																		
	6,7																																		
	6,7																																		
RTS 1160 3S	3,9																																		
	3,9																																		
	3,9																																		
	3,9																																		
RTS 1450 3S	4,6																																		
	4,6																																		
	4,6																																		
	4,6																																		

NOTE: the gas burners must be completed with the gas train.
 NOTE: for specific accessories, connection MODBUS and more details on control panels, please refer to page 325.

HYBRID SYSTEMS

HEAT PUMPS

WALL-HUNG BOILERS

FLOOR-STANDING BOILERS

WATER-HEATERS

SOLAR THERMAL AND CYLINDERS

CENTRALIZED HEATING

AIR CONDITIONING

TERMINAL UNITS

SYSTEM COMPLEMENTARY ITEMS

HOT AIR GENERATORS

Description	Back-pressure in combustion chamber (mbar)	Oil burner												Burner accessory	Burner flange				Control panels																
		Yellow flame (Standard)						Blue flame (Low NOx)							Burner flange	Burner flange	Burner flange	Burner flange	RielloTech Prime	RielloTech Klima Comfort															
		Two stage			Modulating			Two stage			Modulating																								
		-			Mechanical cam			-			Mechanical cam																								
		RG3D	RG4D	RL 50 TC	RL 70 TC	RL 100 TC	RL 130 TC	RL 34 MZ TC	RL 44 MZ TC	RL 50/M TC	RL 70/M TC	RL 100/M TC	RL 130/M TC	RL 28/M TC	RL 38/M TC	BG6:1D	BG7:1D	RL 22 BLU	RL 32 BLU	RL 42 BLU	RL 55/M BLU	RL 85/M BLU	RWF 50.2	RWF 50.2	Burner flange	Burner flange	Burner flange	Burner flange	RielloTech Prime	RielloTech Klima Comfort	Two stage burner management kit	3-point modulation kit			
		3739450	3739750	3474632	3475032	3475232	3475432	3470210	3470310	20166502	20166463	20166481	20166486	20166492	20166497	20015693	20015696	20027479	20027481	20027567	20169338	20169330	20082208	20099869	20043900	4031188	4031196	4031198	20010820	4031069	4031067	20013035			
RTS 90 3S	1,0	●																											●	●					
	1,0														●															●	●				
RTS 115 3S	1,4	●																												●	●				
	1,4															●														●	●				
RTS 166 3S	1,8		●																											●	●				
	1,8																●													●	●				
RTS 217 3S	2,7							●																					●	●	●	●			
	2,7																	●											●	●	●	●			
	2,7																	●											●	●	●	●			
RTS 255 3S	2,9							●																						●	●				
	2,9																													●	●				
	2,9																													●	●				
RTS 349 3S	3,6								●																					●	●				
	3,6																													●	●				
	3,6																													●	●				
RTS 448 3S	2,9			●																										●	●				
	2,9									●																				●	●				
	2,9																													●	●				
	2,9																														●	●			
	2,9																								●					●	●				
RTS 511 3S	5,4			●																										●	●				
	5,4									●																					●	●			
	5,4																														●	●			
	5,4																														●	●			
RTS 639 3S	5,2				●																									●	●				
	5,2																														●	●			
	5,2																														●	●			
	5,2																															●	●		
RTS 850 3S	6,7					●																									●	●			
	6,7																														●	●			
	6,7																															●	●		
	6,7																															●	●		
RTS 1160 3S	3,9						●																								●	●			
	3,9																															●	●		
	3,9																																●	●	
RTS 1450 3S	4,6							●																							●	●			
	4,6																															●	●		

NOTE: for specific accessories, connection MODBUS and more details on control panels, please refer to page 325.

Description	Back-pressure in combustion chamber (mbar)	Dual fuel burner								Burner accessory		Burner flange					Control panels				
		Yellow flame (Standard)				Blue flame (Low NOx)															
		Two stage				Modulating															
		-				Mechanical cam															
		RLS 28	RLS 38	RLS 50	RLS 70	RLS 100	RLS 68/M MX TC	RLS 120/M MX TC	RLS 160/M MX TC	RLS 190/M MZ	RWF 50.2	RWF 50.2	Burner flange	Burner flange	Burner flange	Burner flange	Burner flange	RielloTech Prime	RielloTech Clima Comfort	Two stage burner management kit	3-point modulation kit
RTS 166 3S	1,8	●																●	●	●	
RTS 217 3S	2,7	●																●	●	●	
RTS 255 3S	2,9	●																●	●	●	
RTS 349 3S	3,6		●															●	●	●	
RTS 448 3S	2,9			●														●	●	●	
	2,9						●				●							●	●	●	
RTS 511 3S	5,4				●						●							●	●	●	
	5,4						●				●							●	●	●	
RTS 639 3S	5,2				●						●							●	●	●	
	5,2						●				●							●	●	●	
RTS 850 3S	6,7					●					●							●	●	●	
	6,7							●			●							●	●	●	
RTS 1160 3S	3,9									●	●			●				●	●	●	
	3,9								●		●			●				●	●	●	
RTS 1450 3S	4,6								●	●	●			●				●	●	●	
	4,6							●		●	●			●				●	●	●	

NOTE: for specific accessories, connection MODBUS and more details on control panels, please refer to page 325.

RIELLO

RIELLO S.p.A.
37045 Legnago (VR)
tel. +39 0442 630111
fax +39 0442 630371

March 2021

PRODUCT CATALOGUE

In order to improve its products, RIELLO reserves the right to modify the characteristics and information contained in this catalogue at any time and without prior notice.
This catalogue, therefore, cannot be considered as contractually binding on third parties.

www.riello.com

Code 27017365